

MP3 Player Timer Board Assembly – Part 2

1. Now to add the relays. Locate and solder in the 6VDC DPDT relay as shown. The coil pins are the two that are nearest the bottom of the pic.

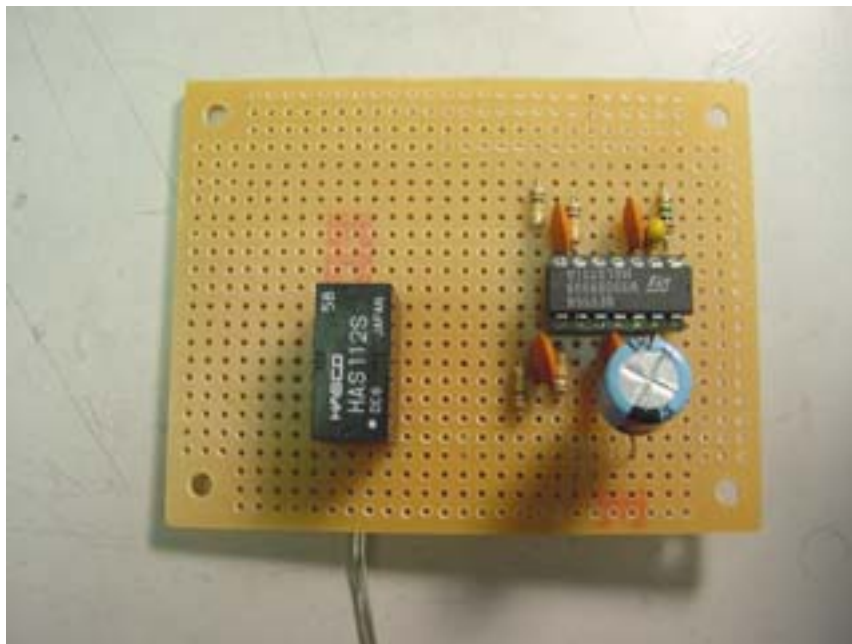

2. Trim the excess positive bus wire as shown.

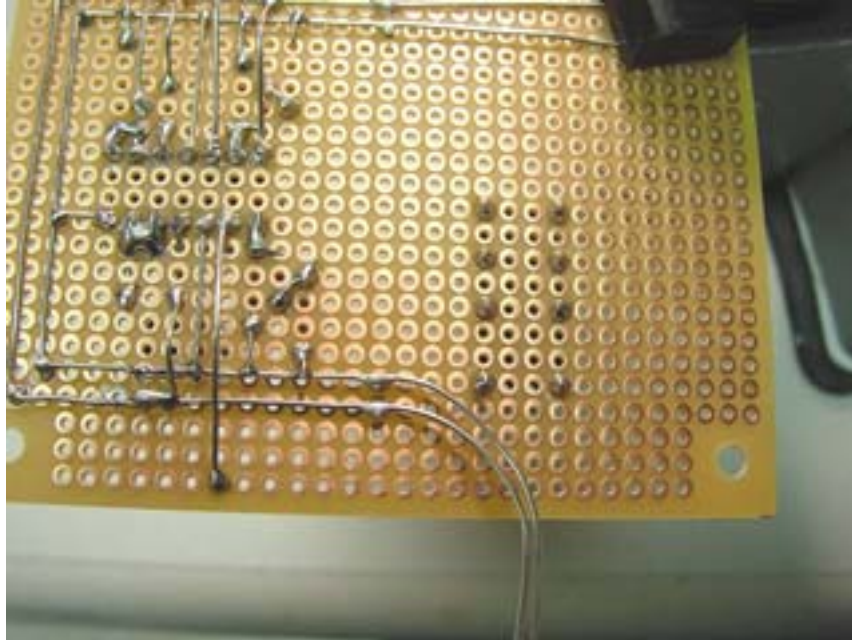
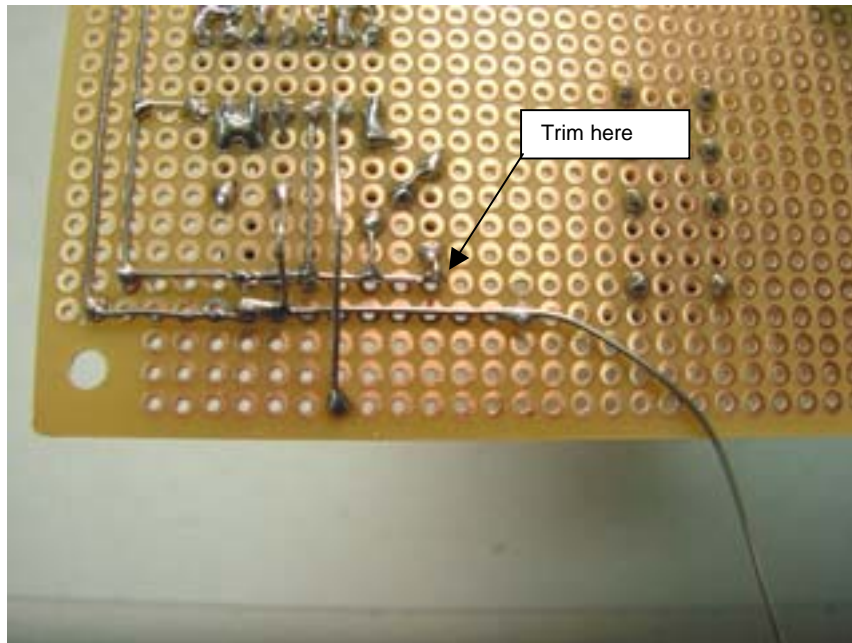

3. Insert the 1N4148 (small) diode as shown. Make sure the black ring on the diode is facing the correct way or the circuit won't work.

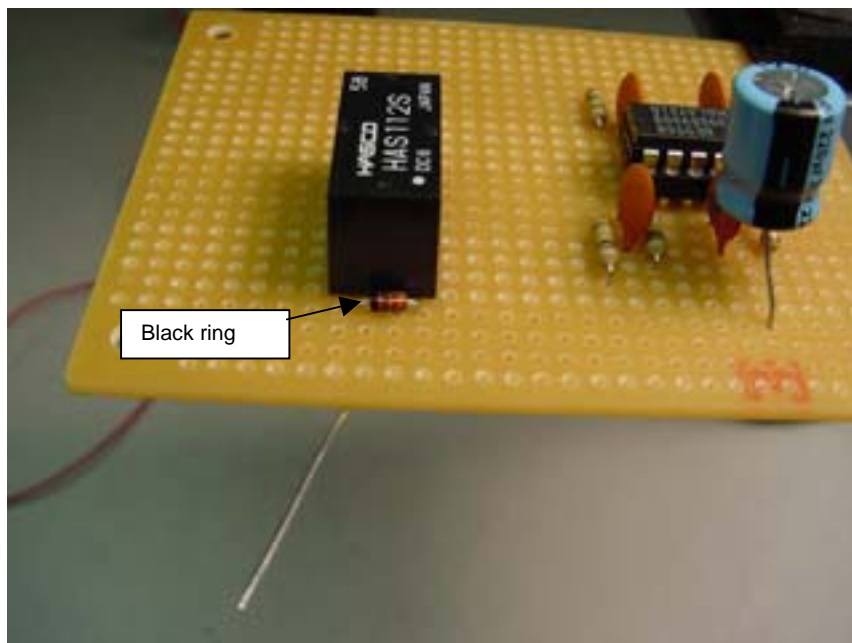

4. Bend the diode legs as shown and solder them to the coil pins of the relay. Trim off the extra wire.

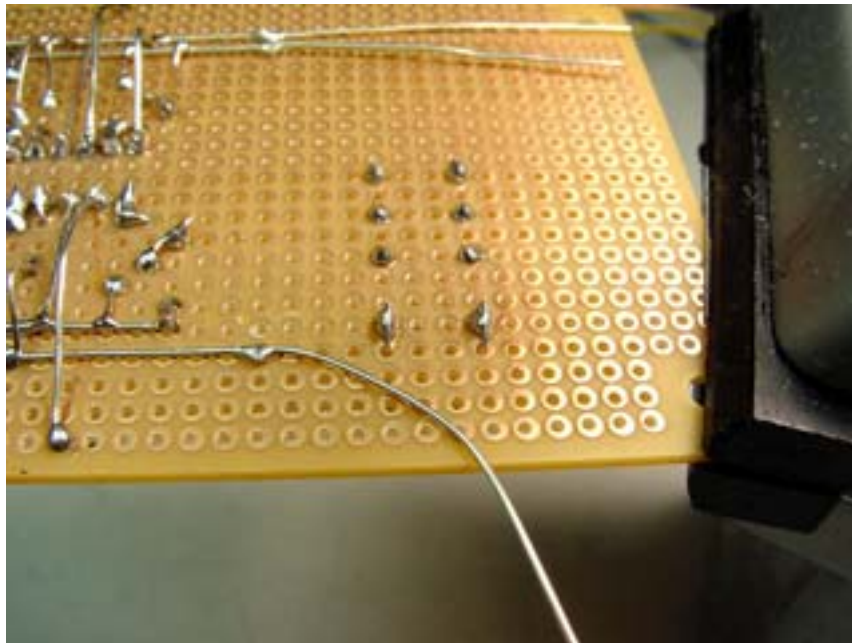
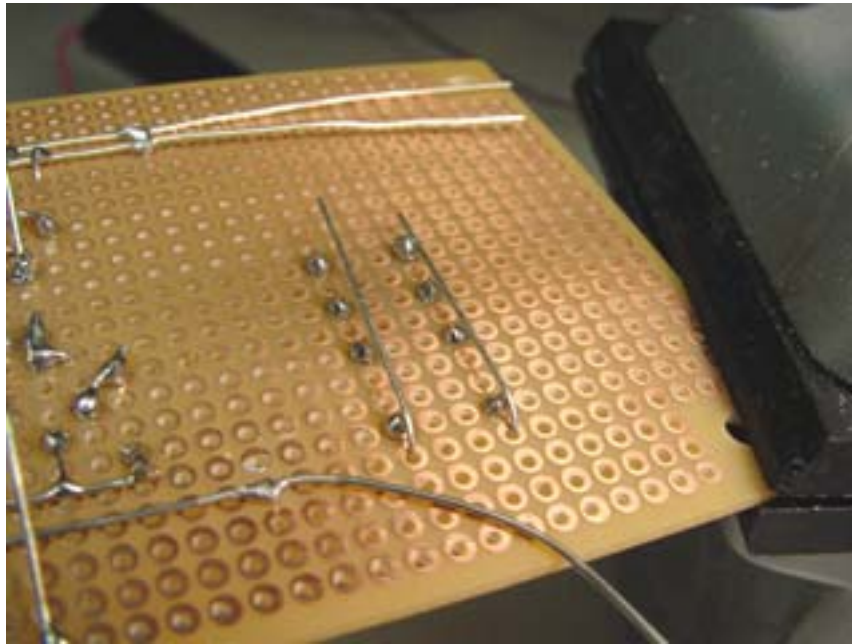

5. Bend the negative bus wire to the coil pin as shown. Solder the wire to the pin and trim.

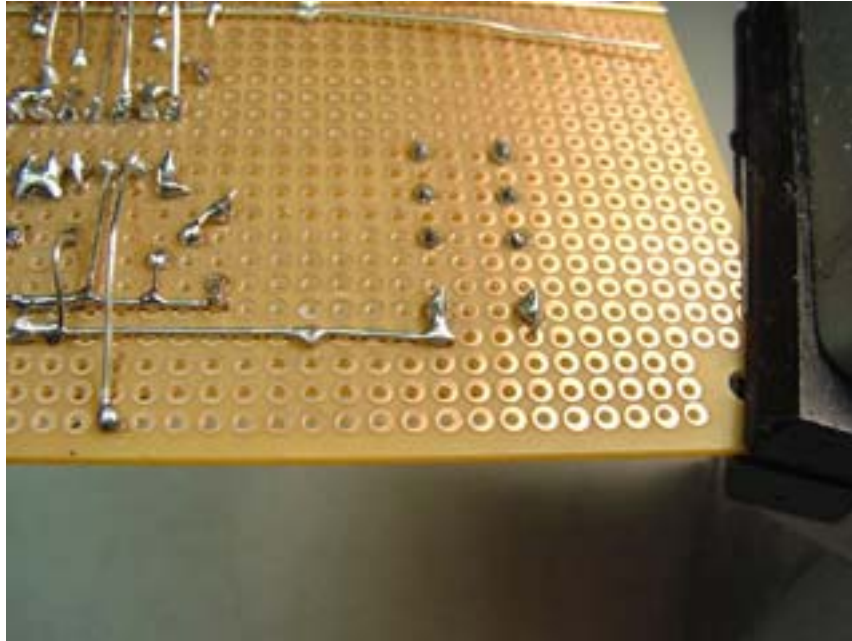

6. Install the 1N4001 (larger) diode and bend the legs as shown. Again, make sure the ring on the diode is facing the correct way (same direction as the small diode).

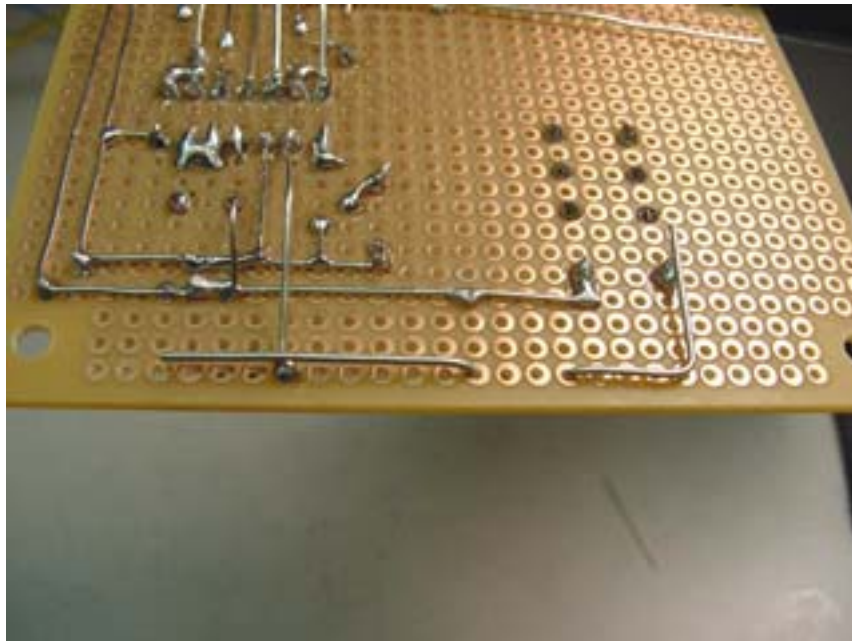

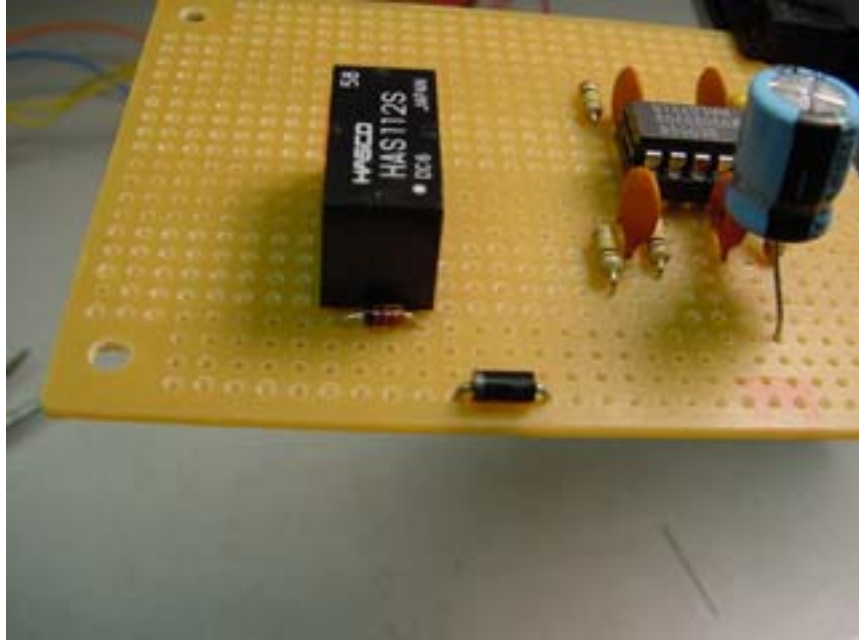

7. Solder the diode wires as shown and trim the excess wire.

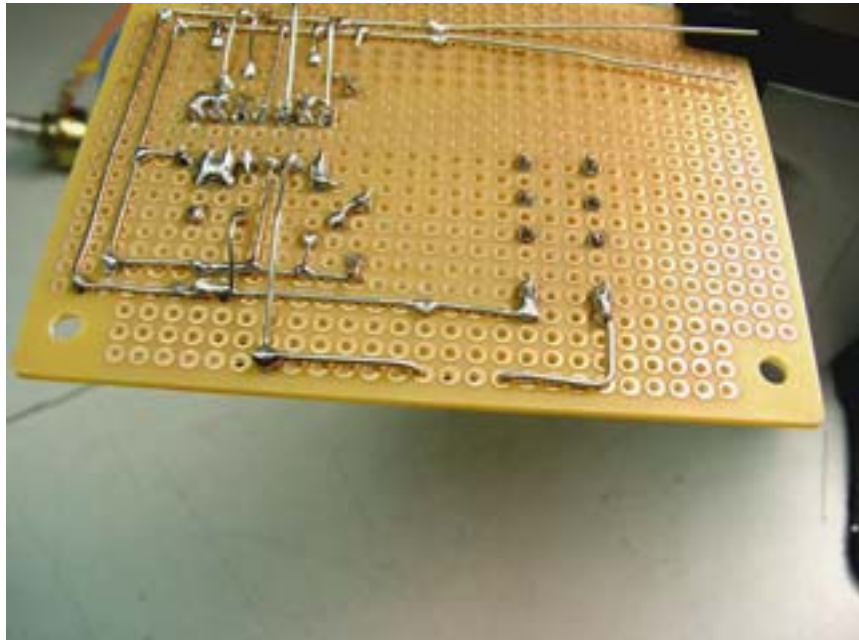

8. Now let's install the 9VDC relay. Trim the positive bus wire as shown and solder in the relay. The coil pins are the two nearest the top of the pic.

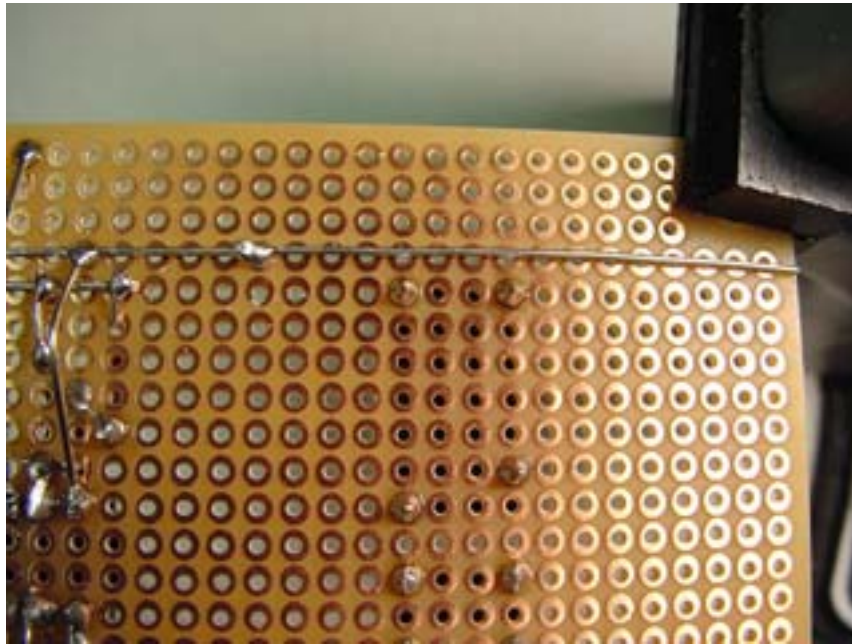

9. Insert and solder in the 1N4148 diode. Verify the direction of the ring.

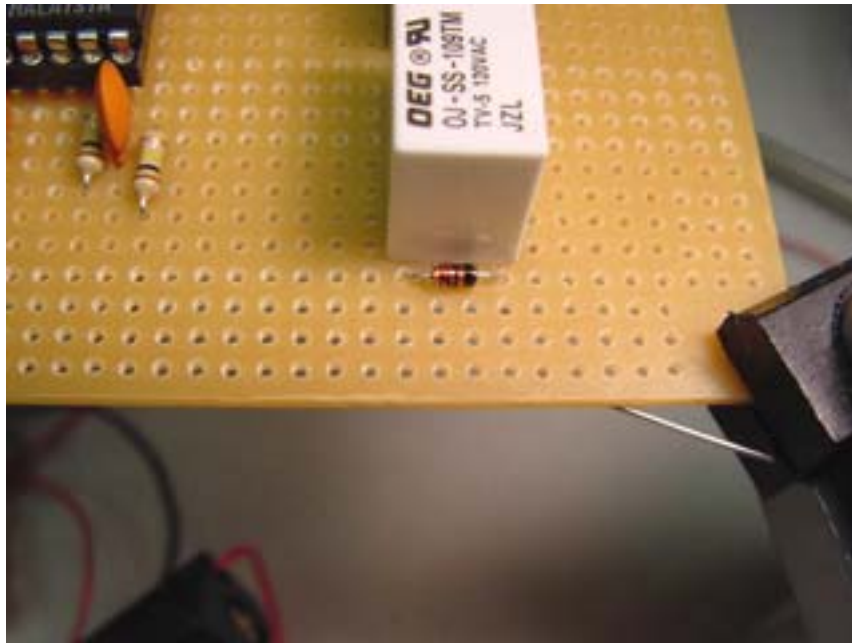
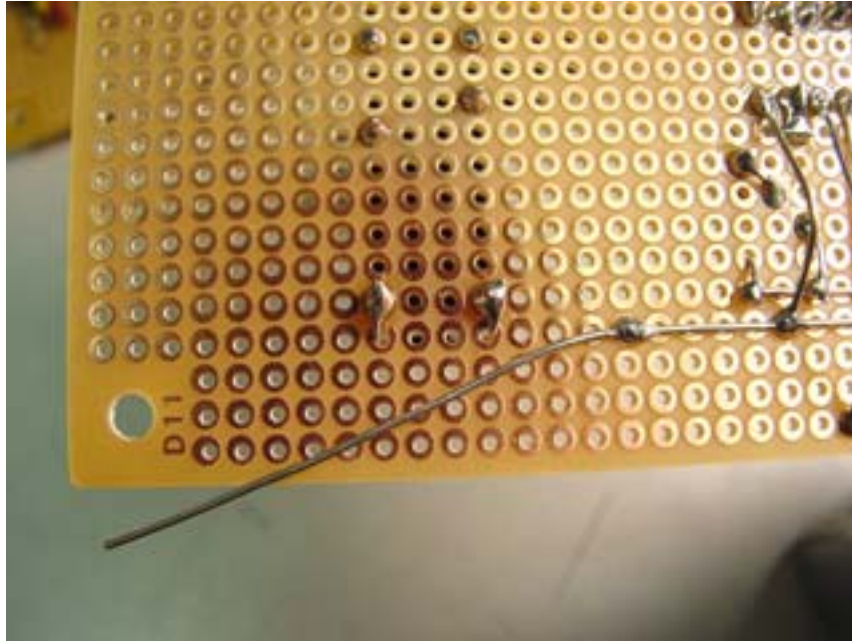

10. Install the large diode as before. I know I'm repeating myself, but check the ring direction before you solder.

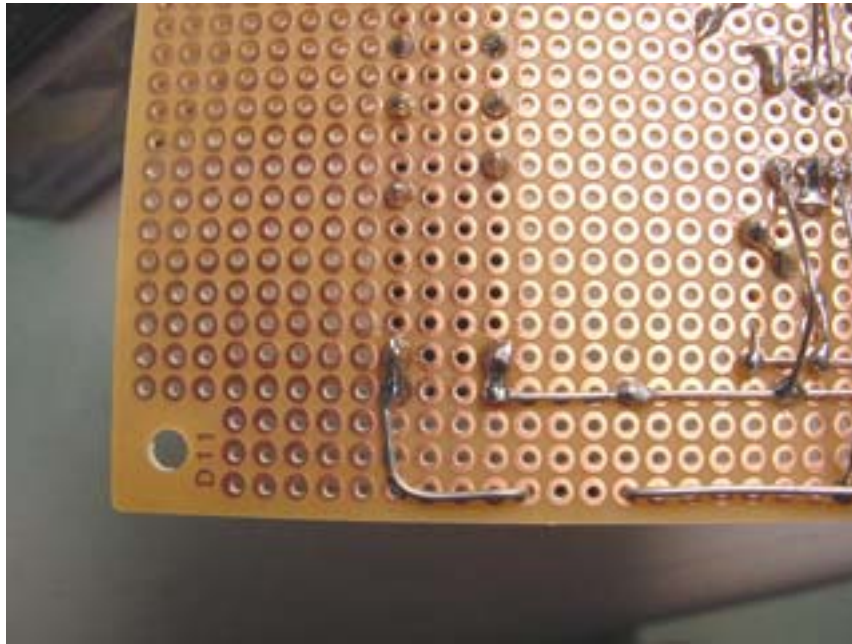

11. Solder a piece of bus wire from the relay contact to the trigger location as shown. Trim off the extra wire.

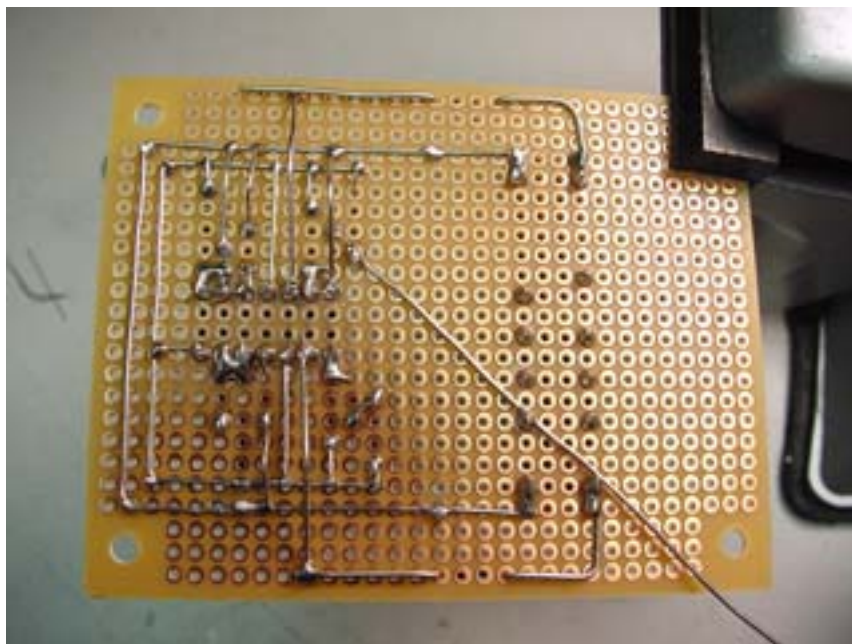

12. Solder a second piece of bus wire from the relay pin to the negative bus wire as shown. These are the wires that will trigger the "button press" timer circuit.

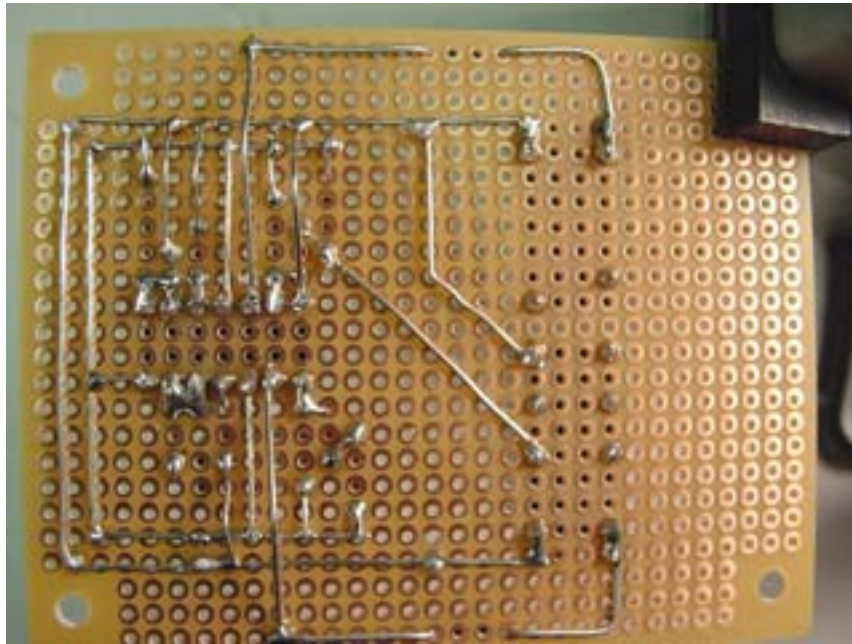

13. If you want to test the circuit, go ahead and solder in the power leads. Red is positive and black negative in the pic.

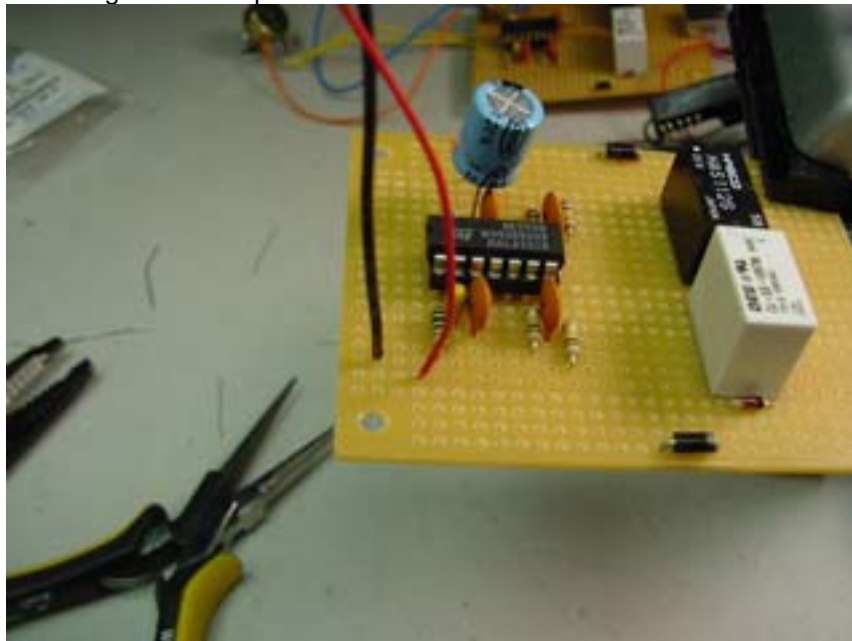

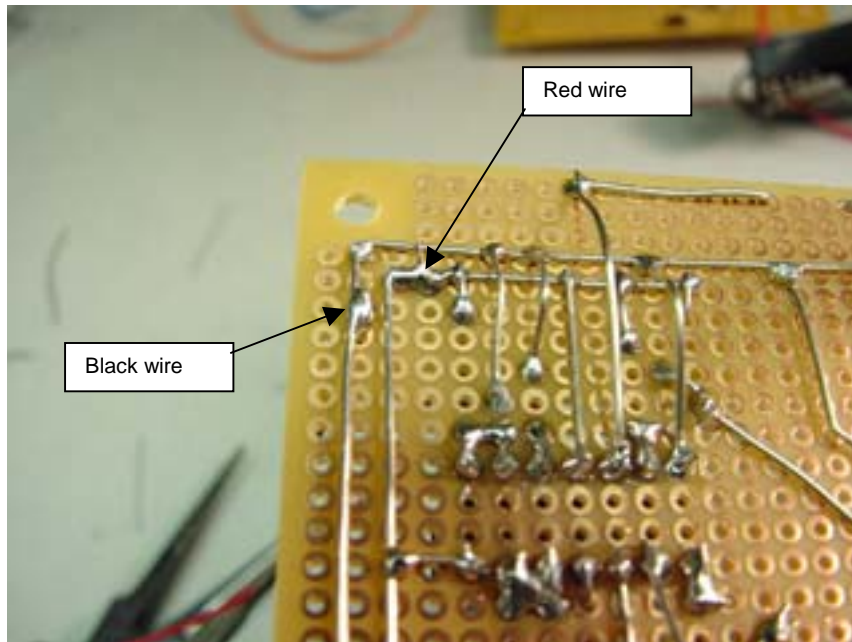

14. Ream or drill out these two holes on the edge of the board. This is where the USB connector will be installed. The holes need to be large enough to fit the clips on the connector.

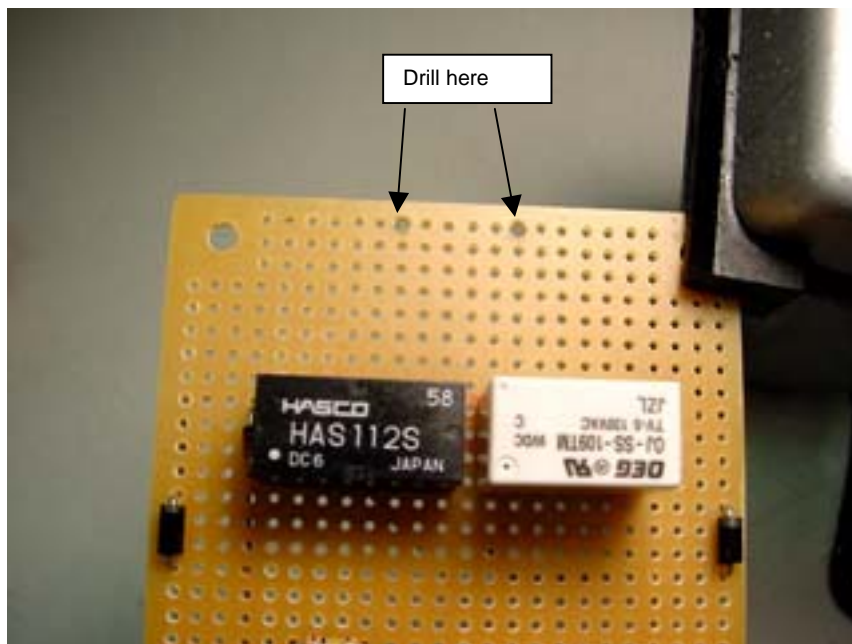

15. Press in the USB connector and solder all four pins to the board.

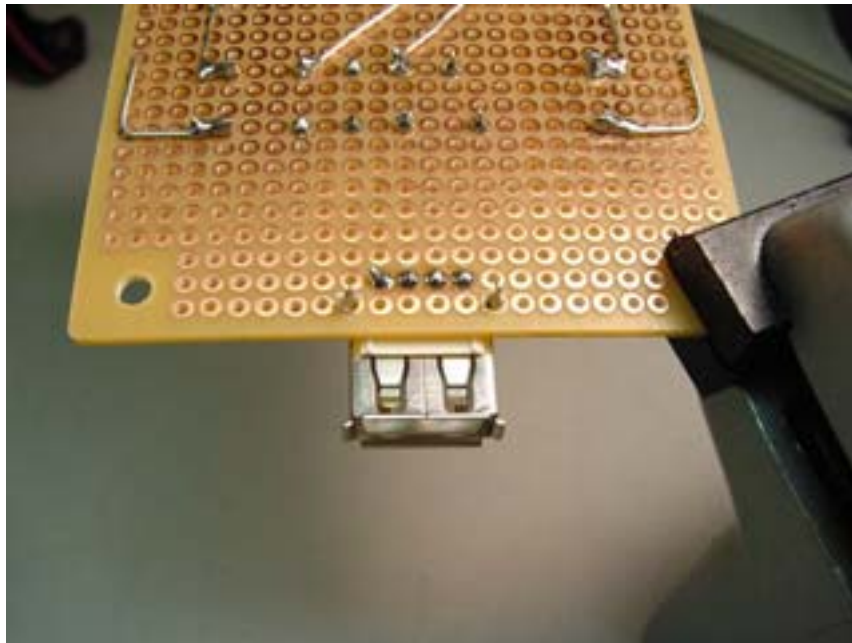
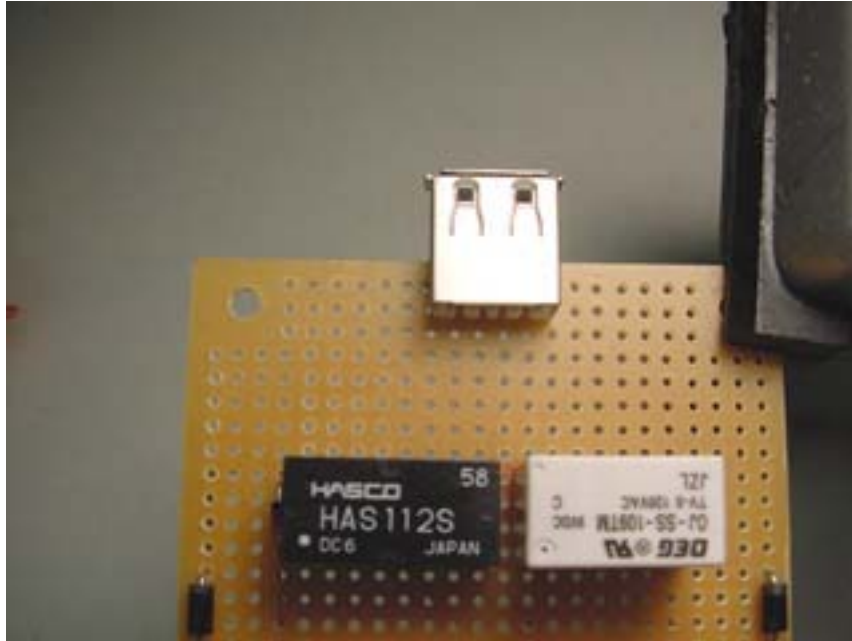

16. Solder a piece of bus wire as shown.

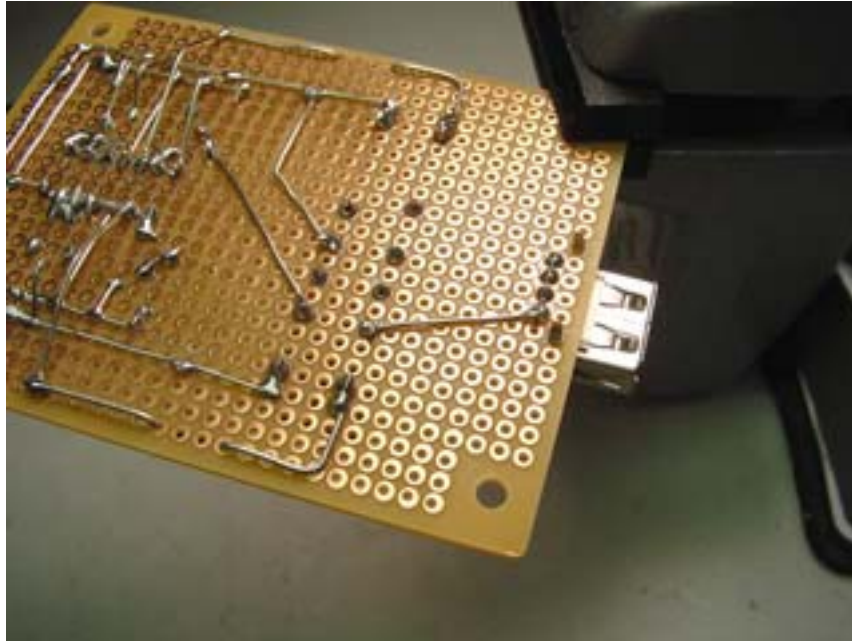

17. Here's what you should have at this point.

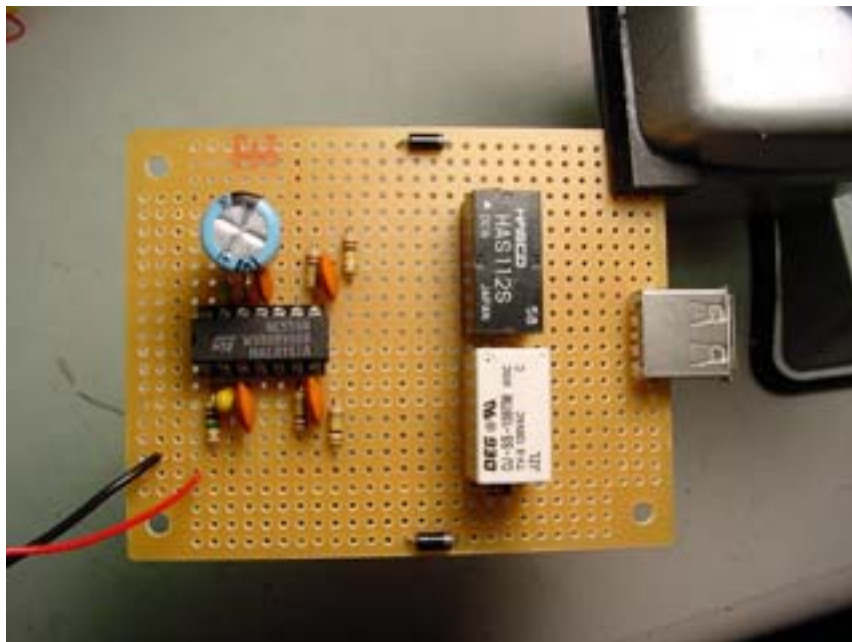

18. If you want to test the circuit, attach a 9-volt battery to the power leads. Caution: make sure you have the polarity correct. If you don't, you'll blow a crater in the 556 chip. To test the timer, momentarily connect the trigger point to the negative bus wire as shown in the pic. You should hear a click as both relays energize, then another click a moment later as the first timer runs out. Since we don't yet have the potentiometer attached, the other relay won't release until you disconnect the power.

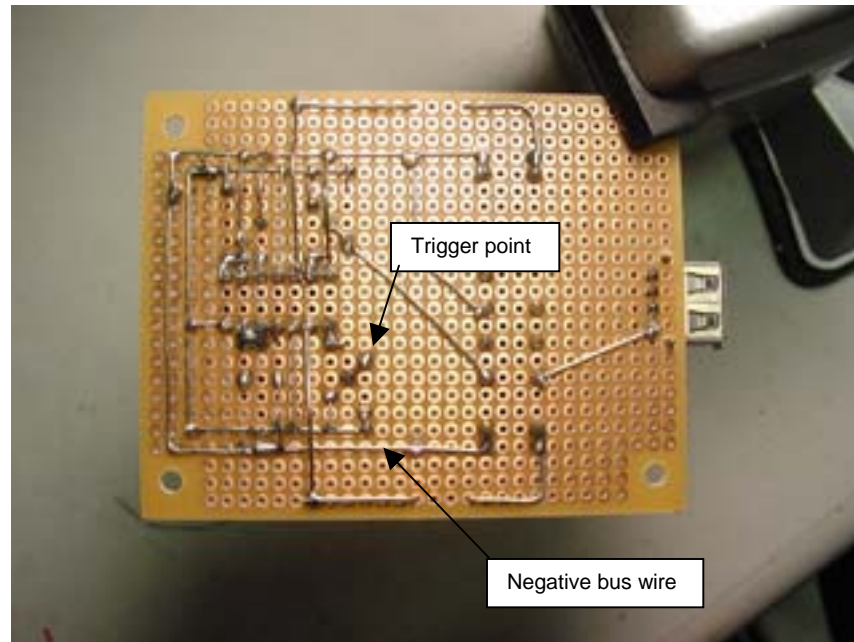

These are all of the components that are soldered to the board. Part 3 of the how-to will detail the battery holders, trigger, potentiometer wiring and installing the board in the plastic enclosure. As always, email me if you have any questions. (<mailto:adamsgd@aol.com>)